

Chapter 15

General Guidelines for Repairing Buried PE Potable Water Pressure Pipes

Introduction

Traditional piping systems have gasket-sealed bell and spigot joints every 20 feet, which can be a potential maintenance and repair point at each connection. Metallic pipes are subject to corrosion which can require constant maintenance over the life of the pipes. A heat fused high density polyethylene (PE) pipeline is not only corrosion and chemical resistant but the leak free joints at 40 to 50 foot intervals are as strong as the pipe itself which provides a maintenance free system except for infrequent unforeseen third party damage. If PE is damaged by a third party, repair methods may be required to bring the piping system back into service as soon as possible. This document will provide general guidelines for repairing PE. They should be useful in establishing procedures and/or specifications for various repair methods to PE piping systems.

For above ground repairs, when the pipe can be moved, the damage can be cut out and replacement pipe can be butt fused or electro-fused into the system.



Figure 1 Above Ground Repair with Fusion Machine

However constrained installations, such as buried pipes, may not allow such movement. Permanent repairs of constrained pipes may require techniques and fittings that do not require longitudinal movement such as spool or flanged assemblies, mechanical or electrofusion couplings, etc.

Caution: Be sure to follow OSHA safety guidelines when uncovering and repairing buried pipelines.

Natural Gas Polyethylene Piping Systems

In this application, only those persons qualified pursuant to a gas company's Operator Qualification program shall make repairs.

Plastic piping systems may be damaged during installation or through third party damage by others once in service. The repair or replacement must be made in accordance with requirements of DOT 49 CFR 192.311. All imperfections or damaged sites that would impair the serviceability of the plastic pipe (significant scratches, gouges or flaws) must be removed or repaired.

Mechanical or electrofusion couplings appropriate for plastic gas piping systems are frequently used for economical and convenient replacement of damaged plastic pipe segments. The gas flow is stopped; the damaged section cut out and replaced with a mechanical repair fitting or a new segment using either two couplings or a fusion joint and a coupling. Joints fabricated from mechanical fittings used in replacement must be designed to restrain the pipe against pullout forces and, if metallic fittings are utilized, be protected against corrosion.

Full encirclement type band clamps have been successfully used with plastic pipe to make repairs. ASTM F 1025 "Standard Guide for Selection and Use of Full Encirclement Type band clamps for Reinforcement or Repairs of Punctures or Holes in Polyethylene Gas Pressure Pipe" provides guidance regarding use of this fitting for repair and reinforcement of polyethylene pipe. The important consideration is that the clamp permanently exerts limited unit-bearing pressure on the plastic pipe since it is not possible to install metal stiffeners inside the plastic pipe in this application. A soft gasket formulation with waffle-type inner surface would generally be preferred for this application. In all cases, the method used should follow procedures that have been established and qualified by test.

Full encirclement type band clamps in compliance with the guidelines of ASTM F 1025 are acceptable for temporary repairs of polyethylene pipe.

Before placing in service, test segments of plastic pipe that are installed to replace damaged sections of mains and services according to the operator's procedures. Leak

test all tie-in joints and the squeeze-off areas at system pressure after the repair is complete. If recommended by the manufacturer, any anti-static fluid should be rinsed from the piping using water. If, in a dig-in situation or a plastic service other than a low pressure service, it appears that the pipe or casing was pulled or moved, and that damage could have occurred at locations along the service other than those inspected or repaired, leak-test the entire service at 100 psig for a minimum of 5 minutes per the operator's procedures. Leak- test low -pressure services at 10 psig for a minimum of 5 minutes per the operator's procedures. If additional damage is found, replace the service.

Municipal and Other Polyethylene Piping Systems

Temporary Field Repairs with Full Circle Band Clamp

Many system operators will have full circle band clamps in their specifications as a repair option. In general these types of repair clamps have proven to be a great method of temporary repair, especially in emergency situations.

Some general design considerations for the successful use of full circle band clamps are as follows:

- Full Circle Band Clamps are recommended for repairs only where the pipe is able to maintain its structural integrity. Consider repairs only to a clean-cut round hole or deep scratches or gouges of maximum dimension, less than the nominal diameter of the pipe divided by three. Do not use band clamps when the pipe has cracks, jagged punctures, long tears, or deep scratches or gouges which could propagate outside the clamp under anticipated field loads.
- Do not exceed the manufacturer's recommended maximum operating parameters such as temperature and pressure.
- The installer should always follow the clamp manufacturer's recommend installation guidelines. Whenever possible, use a product that has been specifically designed for use with polyethylene pipe.
- The manufacturer should always be consulted on the use of their product on polyethylene pipe if the clamp was not manufactured specifically for use with polyethylene pipe.
- Pipe movement due to thermal expansion, thermal contraction and creep, as well as, surge events must be considered when repairing polyethylene pipe with a full circle band clamp.
- Generally, full circle band clamps are intended for use in underground applications. If your application is of a different nature, contact the manufacturer of the band clamp.

If the band clamp is to be used as a permanent repair, contact the fitting manufacturer for the suitability of use as a permanent repair.

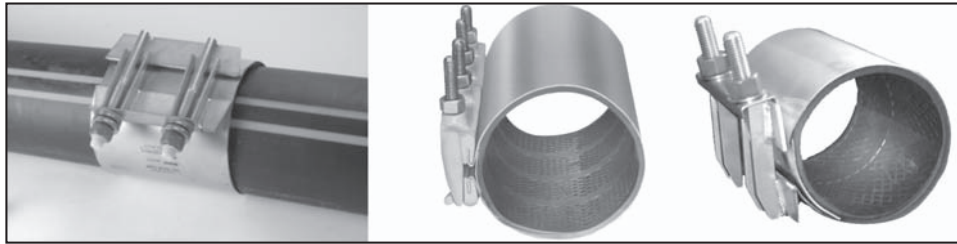

Figure 2 Full Circle Band Clamps

Permanent Field Repairs

Small Field Repairs

Saddle Fusion Repair

If the size of the puncture damage is very small (1 inch or smaller puncture on one pipe wall), a capped off Tapping Tee or High Volume Tapping Tee or patch can be saddle fused to the main over the damaged area, provided the water flow can be stopped and the repair area kept dry during the repair process. Before adding the patch or fitting, drill a small hole at each end of the damage to prevent the crack from propagating further.

Then, butt fuse a cap on the service outlet of the Tapping Tee selected for the repair. Turn off the water and prepare the surface area around the damage for the saddle fusion process (see PPI Generic Saddle Fusion Procedure TR-41). Saddle fuse the fitting over the damaged area using the Generic Procedure and allow the joint to cool. Wait 30 minutes, turn the water back on.



Figure 3 Saddle Fusion Repair

Electrofusion Patch Repair

An electrofusion patch can also be used to repair small puncture damage in the pipe (3 inches or smaller puncture in one wall of the pipe) as long as the water flow can be stopped and the repair area kept dry during the repair process. Use the manufacturer's recommended electrofusion procedure and equipment for saddle fusion.



Figure 4 Electrofusion Patch Repair

Mechanical Fitting Repair

In some cases where the damage is slight but has severed the pipe, the line can be shut off and a small section of the pipe cut out to install a mechanical coupling in the damaged area (see Figures 5, 6, & 7). Contact the coupling manufacturer for the size of damage that can be repaired. A certain amount of the piping system will need to be exposed to allow the pipe to be bent for the installation of the coupling.

Some couplings are self restrained and others are not. Some require a stainless steel stiffener inside the PE pipe and some do not.

For damage to small diameter water service lines (2 inches and smaller), mechanical compression fittings appropriate for PE pipe or tubing are commonly used for the repair. Water flow is stopped, generally using a pinch off tool, and the damaged area evaluated. If it is a small cut or hole, the pipe can be cut in the damaged area and a compression fitting installed between the pipe ends. As required for larger pipe sizes, this method may require a certain amount of the piping system be exposed to allow the pipe to be bent for the installation of the coupling. If the damage is more extensive, a section of pipe is cut out and replaced with a replacement piece of pipe and two compression fittings.

It is recommended that all couplings used with PE should have a stiffener installed to increase the sealing capability of the coupling by minimizing the effects of creep and dimensional changes due to temperature variations (see “Stiffener Installation Guidelines” section in this chapter). It is also recommended that, if the coupling does not provide its own restraint, then external restraints should be utilized on each side of the fitting to prevent pullout due to the thermal expansion or the Poisson effect of the pipe (see “Restraint Methods” section in this chapter). Mechanical fittings have different design advantages and accommodate different sizes. Contact the mechanical fitting manufacturer for more information. Several manufacturers make mechanical fittings specifically for use with PE, including Mueller, Elster Perfection, Victaulic, Dresser, JCM, Ford, Romac, Cascade Water Works and Smith-Blair.

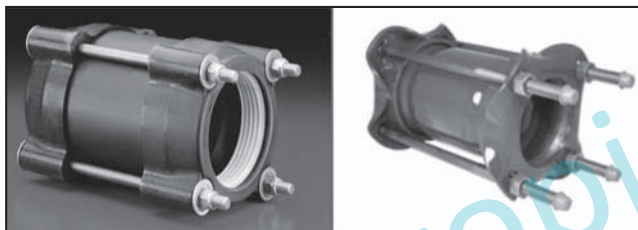

Figure 5 Mechanical Couplings

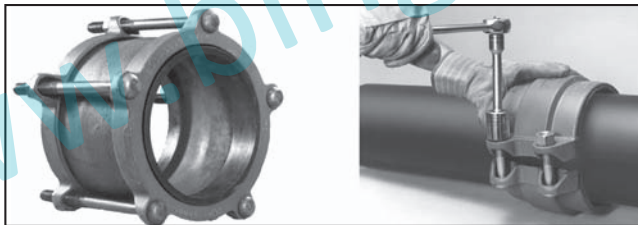

Figure 6 Mechanical Couplings

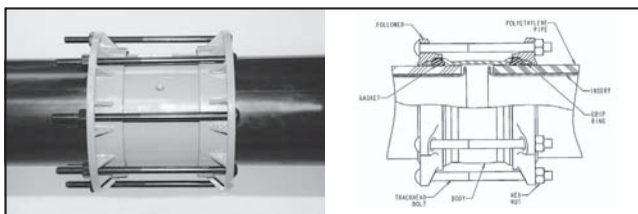

Figure 7 Mechanical Couplings

Large Field Repairs

Mechanical Fitting Repair

If the damage to the pipeline cannot be repaired with a single mechanical coupling as described above, two mechanical fittings can be used by cutting out the damaged pipe (Figure 8 & 9) and making up an assembly with two mechanical fittings and a properly sized and length of polyethylene pipe in the middle. Again, install per the fitting manufacturer's instructions. (Figure 10) A repair to larger pipes requires joining devices for the size of pipe being repaired. However, the various types of joining devices discussed in this section may not be available for all pipe sizes. Contact the joining device manufacturer or supplier for availability and applicability with polyethylene pipe.

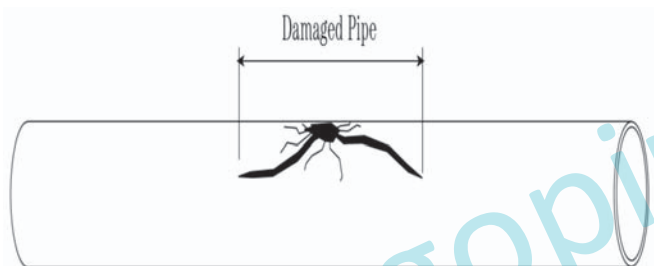

Figure 8 Damaged Pipe



Figure 9 Cut out Damaged Section of Pipe

A saw is needed to cut out the damaged pipe and to cut the replacement section between the cut ends. A wrench is also needed to tighten the bolts. After the damaged section is examined, it can be removed. Damaged PE pipe is usually cut using a dry chain saw. Measure the distance between the cut pipe ends and cut an PE replacement section approximately ½-inch shorter than that length. Install the insert stiffeners in both ends of the existing PE pipes and in both ends of the replacement section.

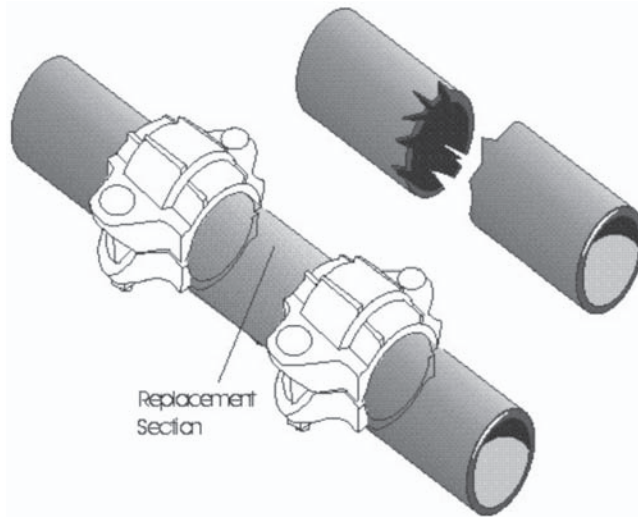

Figure 10 Mechanical Coupling Repair Assembly

Slide the couplings over the replacement section of the pipe and drop the assembly between two cut ends. Then slide the couplings between the replacement section and the cut ends and tighten the bolts using the manufacturer’s procedures.

Caution: Make sure to provide restraints or anchors for the PE pipe if the mechanical couplings are not self restrained. Failure to follow this procedure could result in the pipe pulling out of the coupling (see “Mechanical Restraint” section in this chapter).

As noted above, it is recommended that all PE pipe ends used with mechanical couplings have a stiffener installed to increase the sealing capability of the coupling by minimizing the effects of creep and dimensional changes due to temperature variations (see “Stiffener Installation Guidelines” section in this chapter).

Repairs with Solid Sleeves

Repairs can be made using a mechanical joint (MJ) solid sleeve along with insert stiffeners, restraint device, gasket and tee bolts. A saw is needed to cut out the damaged pipe and to cut the replacement section of PE pipe. A wrench is also needed to tighten bolts. The pipe, gasket and solid sleeve must be cleaned before final tightening of the bolts.

The benefit of this repair method is that it can be made in a wet environment with no special equipment. This is basically the same repair method used for PVC and ductile iron pipe with the addition of insert stiffeners used with PE pipe. The parts are MJ sleeve or sleeves, glands, restraint ring, gasket, extra pipe if large area is damaged, gaskets and tee bolts.

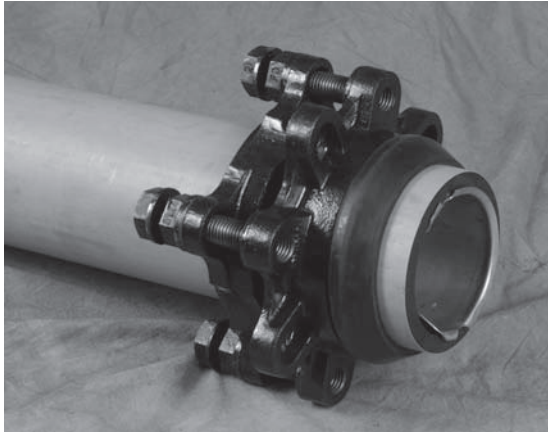

Figure 11 Restraint fitting placed on PE pipe

After cleaning the contact surfaces, and installing a stiffener in existing PE pipe ends and in the ends of the replacement HPDE pipe section, slide the restraint ring and gland over pipe followed by a gasket as shown above. The drawing below shows a typical layout of parts needed to make a repair.

In a repair situation, the MJ sleeve is connected on both ends to PE pipe. The solid sleeve can make up small sections of pipe. If the damaged pipe is longer than the span of a single sleeve, two solid sleeves are used to replace damaged pipe.

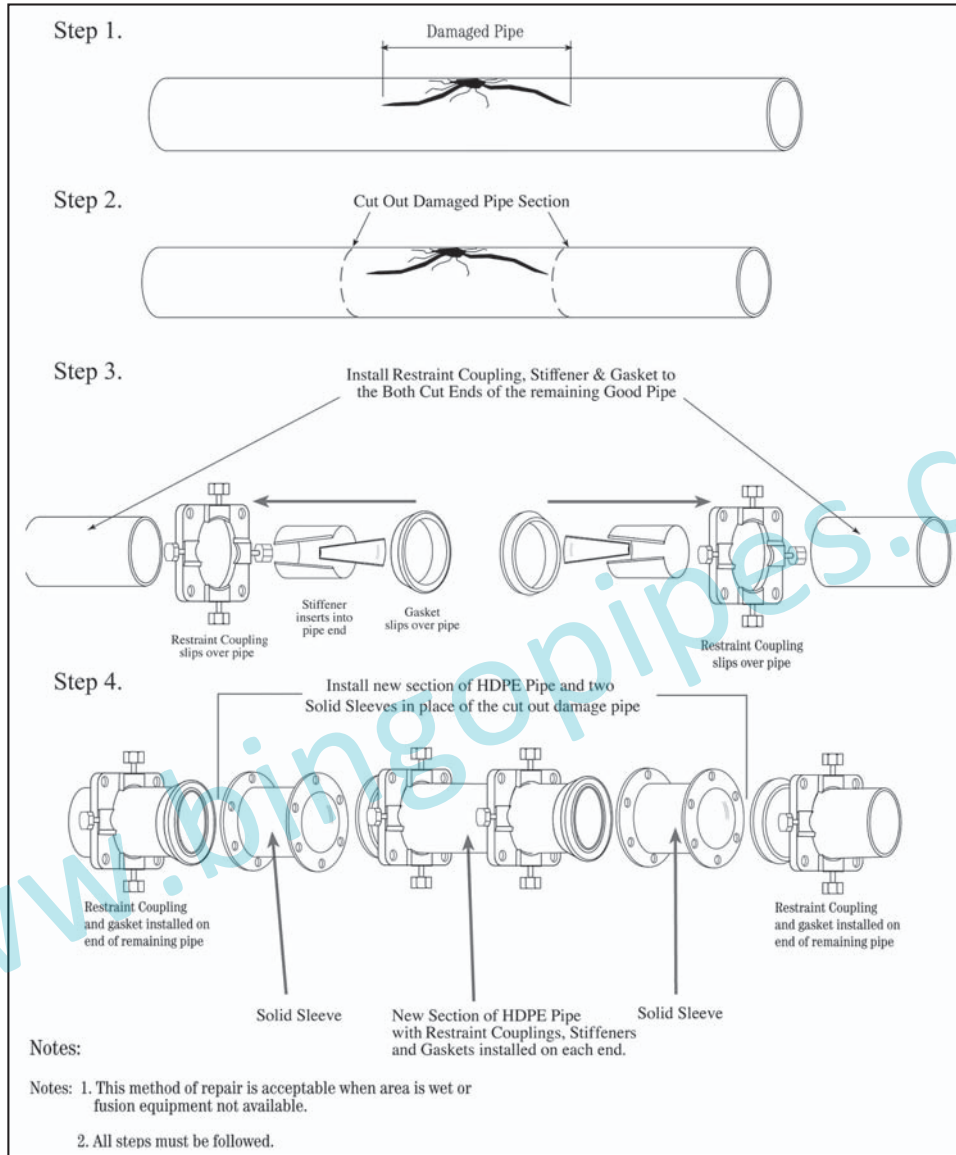

Figure 12 Solid Sleeve Repair Assembly

Flange Adapter Spool Repair

Once pipeline damage has been reported, the size of the pipeline and the DR needs to be established. The correct flange adapter and backup ring size is selected and (4) are required for the repair (see Table 1). The water valve is then shut off and the area excavated and planking installed.

Cut the damaged pipe from the piping system. Make sure that the length removed is long enough for the flange adapter spool assembly to be installed. (See Table 1)

Caution: Butt or Electro-fusion joints cannot be made with water flowing through the pipes. Make sure the water valve shuts-off the water flow 100% and make sure no water is flowing. If a small amount of water is flowing, a towel or pneumatic bladder can be inserted in the valve end to dam up the water long enough to make the butt fusion joint. Be sure to remove this item before making the final connection.

A butt-fusion machine capable of fusing the pipe size is installed in the ditch on planking and clamped to the main pipe. A proper sized flange adapter/back-up ring assembly is installed in the movable jaw. Face the pipe and the flange adapter end to mechanical stops. Remove the pipe chips from the area and align the pipe ends. Using the pipe manufacturer's recommended butt fusion procedures, fuse the pipe to the flange adapter/back-up ring assembly and allow the joint to cool under pressure.

When this joint is cool, remove the fusion machine from the pipe and install the fusion machine's fixed end on the other end of the pipe. Install the proper sized flange adapter/back-up ring assembly in the movable jaw. Face the pipe and the flange adapter end to mechanical stops. Remove the pipe chips from the area and align the pipe ends. Using the pipe manufacturer's recommended butt-fusion procedures, fuse the pipe to the flange adapter/back-up ring assembly and allow the joint to cool under pressure. Also, refer to PPI TR-33.

Once the flange adapters have been fused to the existing pipe ends, measure the inside distance between the flanges. Using the pipe manufacturer's recommended butt fusion procedures, fuse the other two flange adapter/back-up ring assemblies to a piece of pipe with the same OD, DR and specification as the existing pipe to produce an assembly that matches the inside distance between the flanges on the existing pipe. Install the spool piece between the two flanged pipe ends. Bolt the assembly together using the manufacturer's recommended guide for alignment and bolt torque. This will result in a fully restrained joint that does not require thrust blocks or thrust restraints (see Figure 13).

TABLE 1
Minimum Recommended Length of Pipe to Remove for Repair Spool

Pipe Size	Minimum Length of Pipe to be Cut Out for Repair
4" IPS/DIPS	4-5'
6" IPS/DIPS	4-5'
8" IPS/DIPS	5'
10" IPS/DIPS	5'
12" IPS/DIPS	5'
14" IPS/DIPS	5'
16" IPS/DIPS	5'
18" IPS/DIPS	5'
20" IPS/DIPS	5'
22" IPS/DIPS	5'
24" IPS/DIPS	6'

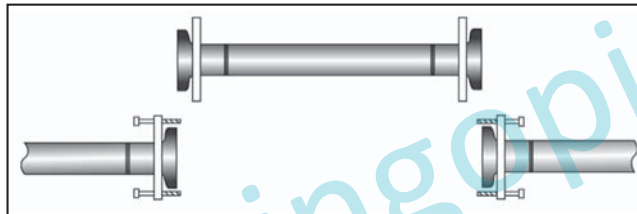

Figure 13 Flange Adapter Repair Spool

Electrofusion Spool Repair

This method is very similar to the Flange Adapter Spool Assembly method, but uses different fusion technology to produce a permanent leak free connection. Instead of butt fusing the pipe ends to flange adapters, electrofusion couplings are used to connect the replacement spool of pipe to the existing undamaged pipe. Consult the electrofusion manufacturer for the detailed joining procedure to follow in making this joint. Here are some general guidelines for follow.

Resistance wires are imbedded into the inside diameter of the electro-fusion couplings to facilitate the fusion joining of the pipe. Fusion is accomplished by energizing the coupling using a processor attached to the fitting. The processor provides the proper amount of energy required to achieve a proper fusion joint.

When damage has been detected, isolate the damaged area by closing valves or utilizing squeeze off tooling. Excavate the damage and determine the extent of the damage. Confirm the size and DR of the pipe to be repaired. The water valve is then shut off and the area excavated and planking installed.

Caution: Make sure the water valve shuts the water flow off 100% with no water flowing. Butt or Electrofusion joints cannot be made with water flowing through the pipes.

Caution: Pipe diameter and surface condition – Before making electrofusion coupling joints, the user must first determine that the pipe diameter and OD surface condition are suitable for electrofusion joining. Consult the electrofusion coupling manufacturer’s instructions for diameter and surface damage limits.

Caution: Joining by qualified persons – Large diameter electrofusion joining is performed only by persons that have personally received training in large diameter electrofusion from the electrofusion coupling manufacturer.

Remove the damaged section of pipe, cutting the ends as square as possible. Cut a spool of the repair pipe to the same length as the removed section of pipe.

On pipe sizes larger than 8” or if the pipe is out of round, it is recommended that a re-rounding tool be installed beyond the area to be scraped. This will help in the scraping process and in the installation of the electro-fusion coupling.

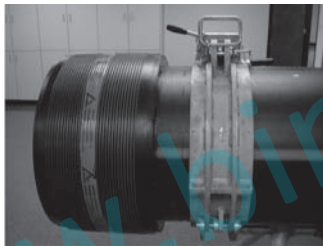

Figure 14 Hydraulic Re-Rounding Clamp Installed



Figure 15 Mechanical Re-Rounding Clamp Installed

Prepare the ends of the spool piece by removing all of the oxidized material from the outside diameter, using a scraper tool. Do not use grinders, emery cloth or other abrasive materials or tools, as they do not completely remove the oxidation.

Prepare each end for the full length of the electrofusion coupling.

Install the couplings completely on each end of the spool piece. Prepare the existing pipe ends in the same manner. Position the spool and move the couplings over the existing pipe ends to be repaired. Provide support for the couplings and the pipe and eliminate any misalignment and stress from the repair area. Using the Electrofusion manufacturers recommended procedures, attach the control box to the fittings and fuse the couplings to both ends of the spool and pipe. This will result in a fully restrained joint that does not require thrust blocks or thrust restraints.

Always follow the manufacturer's installation instructions when installing electrofusion fittings. When making a large diameter pipe repair, refer to the Plastics Pipe Institute Technical Note TN-34.

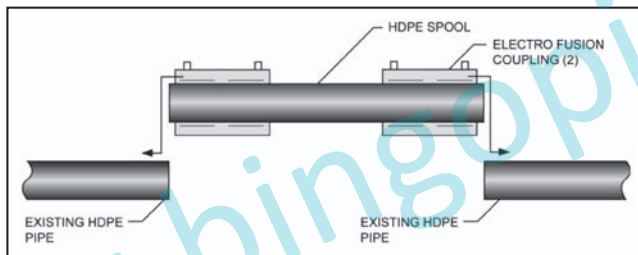

Figure 16 Electrofusion Repair Spool

Stiffener Installation Guidelines

When using a mechanical connection for repair that grips on the OD of the PE pipe, it is recommended that a stiffener be added to the ID of the pipe to insure a good connection between the coupling and the pipe. Check the pipe for toe in, which is an inward curvature of the pipe ends due to residual stress. If it is severe, cut the pipe back to remove it. If possible, have some means to press the stiffener into place. Lubricant will minimize the insertion effort required. A detergent or silicone grease is recommended.

There are two types of stiffeners available on the market. One type is a fixed diameter stiffener that matches the ID of the pipe being repaired (see Figure 17). Caution should be used when using fixed diameter stiffeners to be sure they are sized properly to obtain the proper press fit in the PE pipe. These are mainly used with smaller diameter service lines.



Figure 17 Fixed Diameter Stiffener for PE pipe

The other type of stiffener is a split ring stiffener (see Figure 18). These are normally made of stainless steel and provide a thin yet strong pipe wall reinforcement without disturbing the flow characteristic of the pipe. The easy installation instructions are shown below.

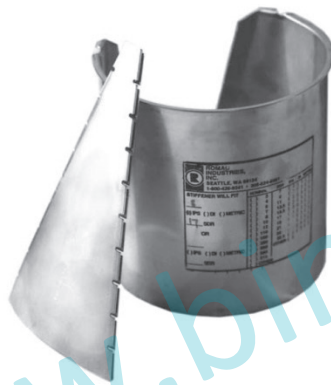

Figure 18 Split Ring Stiffener for PE pipe

Easy Installation...

① Both pipe ends being joined require stiffeners. Insert stiffener into each pipe so that stiffener lip touches pipe end.

② Insert wedge into stiffener. Make sure wedges are not directly opposed.

③ Fix wedge firmly in stiffener by striking with a rubber hammer.

! A stiffener MUST be used in each PE pipe end. Exact SDR of PE used is required when ordering.

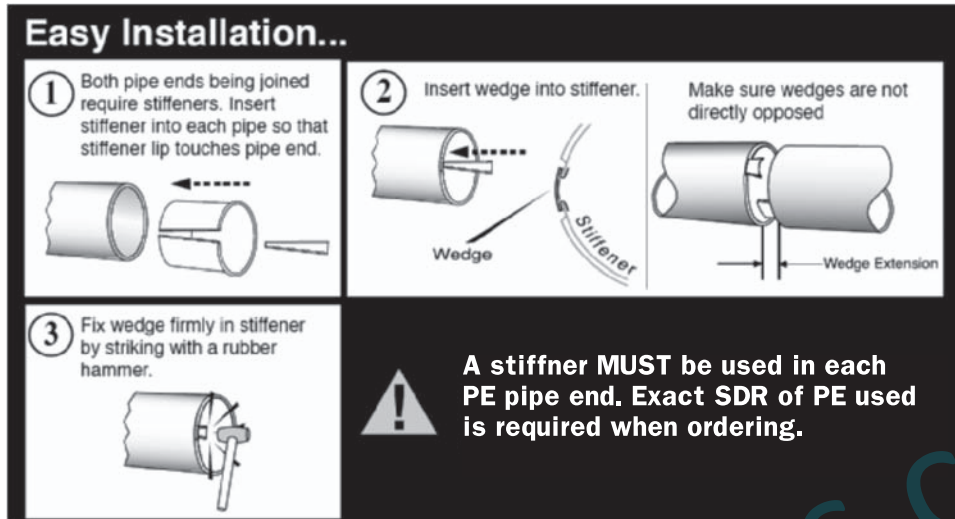
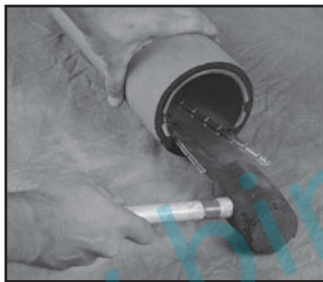



Figure 19 Install Split Ring Stiffener in PE pipe

Restraint Methods

Mechanical Repair Fitting Restraint

The most common method of restraining a mechanical repair fitting is to add a back-up flange to each pipe and electro-fuse the appropriate number of Flex Restraints to each end of the mechanical fitting. The number of Flex Restraints fused to each end depends on the pipe diameter (contact the fitting manufacturer for proper assembly instructions). Once the Flex Restraints have been cooled properly, the mechanical components such as the sleeve, glands, gaskets and bolts can be installed per the manufacturer's procedures to complete the restraining process.

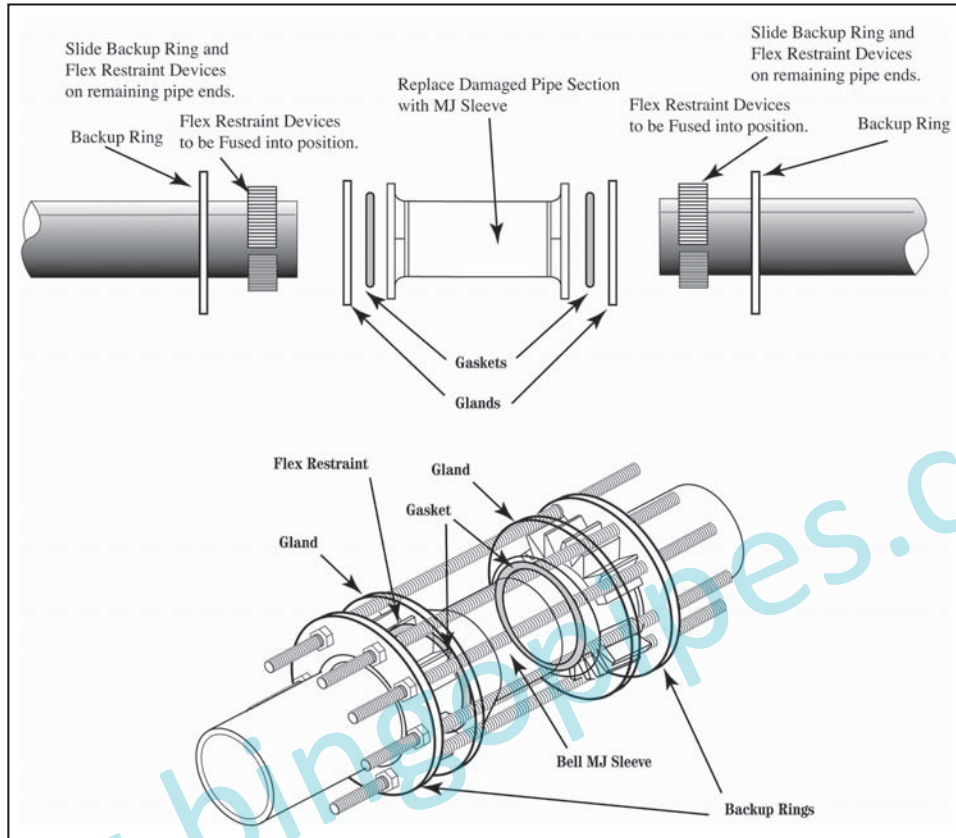

Figure 20 Mechanical Repair Fitting Restraint

Mechanical Coupling Restraint

When the damage is small and a mechanical coupling will satisfy the repair, it may need to be restrained. This is accomplished by using flex restraints (or mechanical restraints) and back up rings on both sides of the coupling. In this situation, the proper quantity of flex restraint couplings are electro-fused to the PE pipe on each side of the coupling (contact the fitting manufacturer for proper assembly instructions). Two backup rings are used with all-thread rods to restrain the connection. Consult the restraint harness manufacturer for the proper assembly procedure.

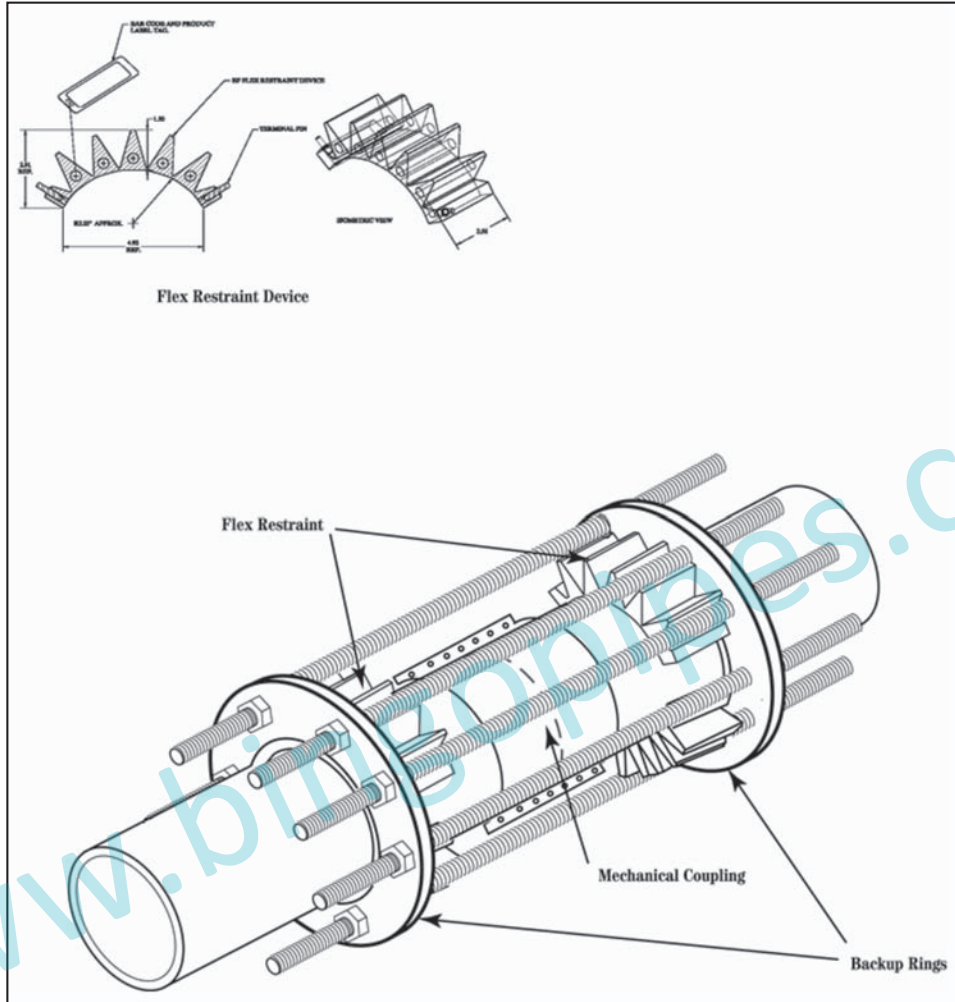

Figure 21 Mechanical Coupling Restraint

Repair Clamps

Third party damage to PE or any pipe material is always a possibility. Repairs can be made by cutting out the damaged section of pipe and replacing the section by use of heat fusion or mechanical fitting technology discussed earlier. Within limits, repairs can also be made with clamp-on repair saddles as depicted in Figure 22. Such devices do have limitations for use. They are intended only to repair locally damaged pipe such as gouges or even punctures of the pipe wall. A clamp length of not less than $1\frac{1}{2}$ " times the nominal pipe diameter is recommended. The procedure is basically to clean the pipe area where the clamp will be placed, and bolt the clamp in place according to the fitting manufacturer's instructions. As with all fittings, limitations on use should be verified with the fitting manufacturer.

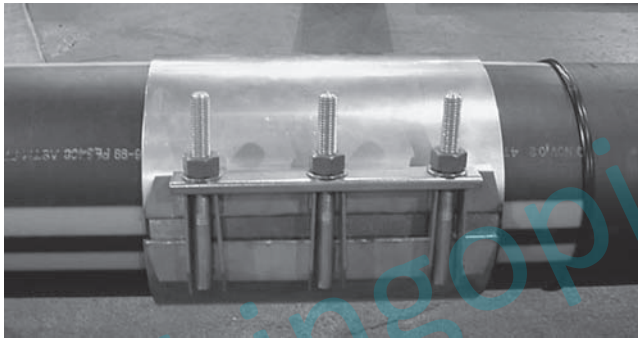

Figure 22 Mechanical Clamp-on Repair Saddle

Squeeze-off

Regardless of the joining method applied in the installation of PE pipe, it may become necessary to shut off the flow in the system. With PE pipe materials, squeeze-off of the pipe with specially-designed tools is a common practice for gas applications. Use squeeze-off tools per ASTM F 1563 and follow the squeeze-off procedures in ASTM F 1041.

534 | **Chapter 15**
General Guidelines for Repairing Buried PE Potable Water Pressure Pipes

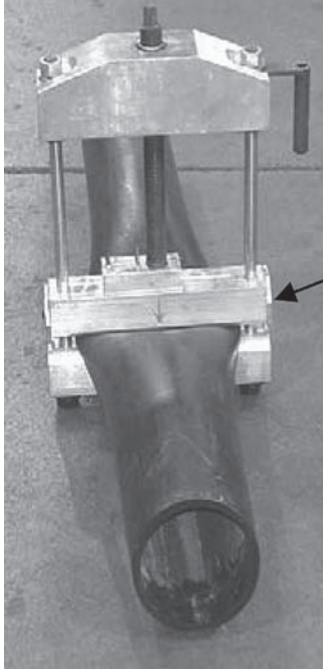

Figure 23 Squeeze-Off Tool

www.bingopipes.com